

FOREST STEWARDSHIP PLAN

FOR

Bay Ridge Civic Association
80 East Lake Drive
Annapolis, MD 21403

LOCATION

Various tracts of land in the
Community of Bay Ridge off of Farragut Road
Annapolis, MD

MD Grid 141,387/446,658
NAD83

IN

Anne Arundel County

ON

90.65 Acres Woodland
93.5 Acres Total

PREPARED BY:

Brian J. Stupak, Project Manager

Will Williams, Regional Education Specialist

January 12, 2004

FOREST STEWARDSHIP PLAN

TABLE OF CONTENTS

Bay Ridge Map Showing Forest Stands

	Pages
Introduction	3
Stand # 1 and 1a Description and Recommended Practices	4-6
Stand #2 Description and Recommended Practices	7
Stand #3 and 3a Description and Recommended Practices	8-9
Stand #4 and 4a Description and Recommended Practices	10-11
Stand #5 and 5a Description and Recommended Practices	12-13
Management Practice Schedule	14
Additional Comments	15-16
Wildlife Management Recommendations	17-18
Non-Commercial Timber Stand Improvement	21
Chesapeake Bay Critical Area/Forest Management Buffer	22-23
Invasive Vines and Weed Species	24-25
Protecting the Forest From Wildfire	26
What are FIDS	27
Brush Piles	28-29
Squirrel Nest Boxes	30-31
Representative Species to Plant at Field Edges to Benefit Wildlife	32
Hard and Soft Edges	33

INTRODUCTION

The Bay Ridge Civic Association (BRCA) owns 93.5 acres of land, 90.65 of which are

wooded, at various locations in the Bay Ridge community in Annapolis, Maryland. BRCA wishes to manage their property to improve the soil and water attributes and the natural heritage & recreational opportunities of the property. These goals correspond to the Stewardship objectives of **soil and water conservation** (primary objective) and **natural heritage and recreation** (secondary objectives). This Forest Stewardship Plan will recommend practices that will be a balance of the needs of the landowner and the forest. The BRCA contact is Mr. William Street. Mr. Street can be reached at 410-268-1188.

PROPERTY OVERVIEW

The property is located along Farragut Road, Herndon Avenue, East Lake Drive, West Lake Drive, Lawrence Avenue and Hull Avenue in Annapolis, MD. The property is a mix of flat and rolling terrain. Three tidal wetlands (E1OWL, E2EM5P, E2EM5/FLN) and one non-tidal wetland (POWZ) are located on the property. Additionally, approximately 87% of the property lies within the Chesapeake Bay Critical Area. See the individual Stand Descriptions and the Additional Comments section for more information regarding Critical Area laws and regulations. The property is bordered on three sides by Balckwalnut Creek, the Severn River, Lake Ogleton and the Chesapeake Bay. The forest is composed of predominantly hardwoods with remnants of pine located in small sections of the property.

NATURAL HERITAGE RECOMMENDATIONS

The term “Natural Heritage” is used to describe the plants, animals, and natural ecosystems that make up the landscapes of Maryland. Thus, Natural Heritage Stewardship is concerned with preserving the plants, animals, and ecosystems of the state for the many benefits they provide us, especially those determined to be threatened, endangered, or in need of conservation. The DNR-Natural Heritage Program maintains a database that has indicated that a nearby area of shoreline is for waterfowl concentration and staging areas. DNR Heritage Service has stated that forestry management practices will not impact these areas.

In addition, your property provides an important habitat for a group of bird species that are considered in need of conservation. These groups of bird species are collectively called “Forest Interior Dwelling Species” (FIDS). An information sheet about FIDS is included with this plan. In a general sense, the natural heritage and recreational opportunities of your woodland can be enhanced through a variety of forest management practices, which can increase habitat diversity and food sources for wildlife. This will provide frequent recreational opportunities for watching birds and other animals, and promote a diverse forest habitat.

STAND DESCRIPTION AND RECOMMENDED PRACTICES

STAND NUMBER: 1 & 1a

AREA ACRES: 63.6 & 0.2

DOMINANT OVERSTORY SPECIES: Tulip poplar, sweetgum, sassafras

DOMINANT UNDERSTORY SPECIES: English ivy, Japanese honeysuckle, American holly

TIMBER SIZE: Sawtimber

AGE: even (40-60 years)

STOCKING: fully stocked (98%)

GROWTH POTENTIAL: excellent

SOIL: Monmouth Loamy Sand (MuA, MuB2, MuC2, MuD2, MuD3)

RECOMMENDATIONS/PRACTICES:

This 63.8 acre stand is composed mainly of sawtimber sized tulip poplar (75%), sweetgum (16%) and sassafras (2%). Northern red oak, southern red oak, hickory and black cherry are scattered throughout. The tree density (or stocking) in this stand is adequate in relation to maintaining the optimum growing space per tree. This means that each tree has enough sunlight, water, nutrients and growing space to properly grow.

This stand is located in the southern and central portions of the property and is classified as bottomland hardwoods. The terrain varies from rolling to flat. The understory ranges from thick patches of greenbriar to sparse patches of holly and spicebush. English ivy and Japanese honeysuckle are pervasive throughout the stand. The ivy is of particular concern as it has climbed the trunks of a majority of the trees in the stand. Trails are located throughout the stand. Two tidal wetlands (E1OWL, E2EM5P) and one non-tidal wetland (POWZ) are located in the stand. 86% of the stand lies within the Critical Area. The Critical Area is defined as all land and water within 1000 feet of the mean high waterline. Forestry operations are regulated by law in this area. Additionally, Stand 1a is the 100 foot Habitat Protection Area and is covered by specific regulations. No forestry work is required in the Habitat Protection Area.

The stand is currently growing well (site index 110 for tulip poplar). However, in three years (2007) it has been calculated that the stand will become overstocked. At that time, each tree will not have enough sunlight, water, growing space, and nutrients to grow properly and growth rates will start to diminish. Starting in 2007, the stand should undergo a Timber Stand Improvement (TSI) in the form of a light basal area thinning. The residual basal area after thinning should be no less than 100 sq. ft/ac. This will allow the remaining trees to continue to grow properly. The trees to be removed should be of poor form and quality (i.e. crooked, forked or leaning). The trees can either be girdled or cut and felled. Girdling is the process of deadening a tree and leaving it standing on the stump to serve as wildlife habitat. Girdling entails making a circular cut with a chainsaw or axe completely around the circumference of the tree. The cut must be deep enough into the cambium of the tree to stop the flow of nutrients.

Two parallel cuts are recommended for trees such as tulip poplar that can heal over just one cut. At least two trees per acre should be left to serve as den trees. Upon request, the Project Forestry Office is available to mark the trees that should be girdled or felled. There is a nominal fee for tree marking (\$12/acre); contact the forestry office for further assistance.

The felled trees may be used as a source of firewood. The following information summarizes the various characteristics you should look for in a piece of firewood.

Species	Easy to Split	Ease of Starting	Heavy Smoke	Sparks	Coaling Qualities
Red Oak	yes	poor	no	Few	excellent
White Oak	yes	poor	no	Few	excellent
Black Locust	no	poor	no	very few	excellent
Hickory	yes	fair	no	moderate	excellent
Red Maple	yes	poor	no	Few	excellent
Gum	no	fair	medium	Few	fair
Yellow Poplar	yes	easy	medium	moderate	fair
American Beech	no	poor	no	Fair	good
Pine	yes	easy	medium	moderate	fair

The following are recommendations for seasoning firewood:

1. Cut and stack firewood in early spring before the trees bud. If not possible, wait until leaves have formed. When cutting trees in leaf, allow them to lie about two weeks before cutting up.
2. Split wood dries faster, so split all wood before piling. Pile wood to take advantage of prevailing winds in a crisscross pattern with the wood bark side up. Space rows a few feet apart to allow for air circulation.
3. The best drying time is March through May.
4. Do not stack wood close to the house. Termites and snakes love woodpiles.

The thinning should be implemented at a rate of 5.3 acres/year and should be completed by January 2019 at which time the stand should be re-examined to update the management recommendations.

In addition to the future overstocking of the stand, Stand #1 has large concentrations of English ivy and Japanese honeysuckle. Both are invasive, non-native plant species that spread along the ground and can climb up trees and shrubs, pulling down trees or covering their foliage. In either case, if left unchecked, they can cover large areas of land and will out-compete native species. Eradication is very labor intensive and use of herbicides can be costly and potentially harmful to the environment.

Eradication will take place in three stages. Stage one will consist of removing vines from tall trees. This can be accomplished by cutting the vines on the tree and applying a herbicide such as Garlon 3a to the lower stems. Care must be taken when applying herbicides to only target the vines and not to apply the herbicide to the tree. Herbicides should not be used in Stand #1a. Some herbicides are restricted and their application can only be performed by a licensed applicator. Contact the Maryland Department of Agriculture (<http://www.mda.state.md.us>) for more information concerning pesticide applicator's licensing.

Stage two will consist of removing the vines from small trees and shrubs. The vines can be cut at the base or pulled from the ground. If the shrub is short enough, the vines can be removed from the entire shrub.

Stage three will consist of removing the vines from the forest floor. This will be the most difficult stage. Applying herbicides to the forest floor could potentially harm other species (holly, mountain laurel, spicebush, etc.). Therefore, mowing, trimming or pulling the vines on a regular basis (at least 3 times a year) is the recommended practice. Vine control should start immediately and should be continuous until all vines have been removed.

STAND DESCRIPTION AND RECOMMENDED PRACTICES

STAND NUMBER: 2

AREA ACRES: 3.4

DOMINANT OVERSTORY SPECIES: Sweetgum, tulip poplar, southern red oak

DOMINANT UNDERSTORY SPECIES: American holly, greenbriar, English ivy

TIMBER SIZE: Sawtimber

AGE: even (85-95 years)

STOCKING: overstocked (118%)

GROWTH POTENTIAL: excellent

SOIL: Monmouth Loamy Sand (MuC2, MuD2)

RECOMMENDATIONS/PRACTICES:

This 3.4 acre stand is composed mainly of sawtimber sized sweetgum (25%), tulip poplar (14%) and southern red oak (14%). White oak, northern red oak, black cherry and red maple are scattered throughout the stand. The tree density (or stocking) in this stand is high in relation to maintaining the optimum growing space per tree. As trees in the stand continue to grow larger, growing space per tree will continue to decrease. This creates an "overstocked" condition where the stand will become less vigorous due to excessive competition for limited resources such as soil nutrients, water, and sunlight. In this overstocked condition, a stand is vulnerable to insect and disease infestation as well as decline from drought.

This stand is located in the southern portions of the property. Two tidal wetlands (E2EM5P & E2EM5P/FLN) are located in the stand. Blackwalnut Creek is located at the southern boundary of the stand. The entire stand lies within the Critical Area. The Critical Area is defined as all land and water within 1000 feet of the mean high waterline. Forestry operations are regulated by law in this area. Additionally, Stand 2 also is the 100 foot Habitat Protection Area and is covered by specific regulations. No forestry work is required in the Habitat Protection Area.

Due to the Habitat Protection Area and the proximity to Blackwalnut Creek, no management practices are required in this stand. It is recommended that this stand continue to serve as a riparian forest buffer, trapping sediment and nutrients before they reach the creek and wetlands.

Allow the forest to grow for fifteen years (2019) at which time the stand should be reexamined to update the management recommendations.

STAND DESCRIPTION AND RECOMMENDED PRACTICES

STAND NUMBER: 3 & 3a

AREA ACRES: 11.15 & 0.05

DOMINANT OVERSTORY SPECIES: Tree of Heaven, sweetgum, tulip poplar

DOMINANT UNDERSTORY SPECIES: English ivy, Japanese honeysuckle, greenbriar

TIMBER SIZE: Sawtimber

AGE: even (40-60 years)

STOCKING: fully stocked (81%)

GROWTH POTENTIAL: excellent

SOIL: Donlonton Fine Sandy Loam (DnB2), Monmouth Loamy Sand (MuB2), Monmouth Fine Sandy Loam (MvB2)

RECOMMENDATIONS/PRACTICES:

This 11.2 acre stand is composed mainly of sawtimber sized tree of heaven (33%), sweetgum (28%) and tulip poplar (28%). Black cherry is also scattered throughout the stand. The tree density (or stocking) in this stand is adequate in relation to maintaining the optimum growing space per tree. This means that each tree has enough sunlight, water, nutrients and growing space to properly grow.

This stand is located in the northwestern portion of the property. Trails are located throughout the stand. 71% of the stand lies within the Critical Area. The Critical Area is defined as all land and water within 1000 feet of the mean high waterline. Forestry operations are regulated by law in this area. Additionally, Stand 3a is the 100 foot Habitat Protection Area and is covered by specific regulations. No forestry work is required in the Habitat Protection Area.

Currently, the stand is growing well (site index 96 for tulip poplar). However, this stand is being overtaken with English ivy, Japanese honeysuckle, raspberry and greenbriar. It is recommended that these vines be removed, using the methods described in the Stand #1 Recommendations . The southern portion of this stand has very little trees, which will allow the use of tractors and bushhoppers to cut down the vines. Vine control should begin immediately and should be continuous until the vines have been eradicated.

Ailanthus altissimo, or Tree of Heaven, is found in this stand. This tree is a non-native species that is extremely adaptable to various site conditions. It is recommended that all

Ailanthus trees be girdled and/or felled. *Ailanthus* is a vigorous stump sprouter and may require several girdling treatments to deaden the tree.

Except for the vine removal and *ailanthus* girdling, allow the stand to grow naturally for another fifteen years (2019), at which time the stand should be re-examined to update the

management recommendations.

STAND DESCRIPTION AND RECOMMENDED PRACTICES

STAND NUMBER: 4 & 4a

AREA ACRES: 4.3 & 0.05

DOMINANT OVERSTORY SPECIES: Tulip poplar, sycamore, sweetgum

DOMINANT UNDERSTORY SPECIES: English ivy, Japanese honeysuckle, spicebush

TIMBER SIZE: Sawtimber

AGE: even (30-40 years)

STOCKING: fully stocked (80%)

GROWTH POTENTIAL: excellent

SOIL: Donlonton Fine Sandy Loam (DnB2), Monmouth Loamy Sand (MuB2), Monmouth Fine Sandy Loam (MvB2)

RECOMMENDATIONS/PRACTICES:

This 4.35 acre stand is composed mainly of sawtimber sized tulip poplar (67%), sycamore (5%) and sweetgum (5%). White oak southern red oak, red maple and sassafras are scattered throughout. The tree density (or stocking) in this stand is adequate in relation to maintaining the optimum growing space per tree. This means that each tree has enough light, space, nutrients and water to grow properly.

This stand is located in the northwestern portion of the property. This stand borders a tidal wetland (E1OWL) and a portion of Lake Ogleton. Currently, this stand is fully stocked and is growing well. The terrain slopes downward towards the lake. The entire stand lies within the Critical Area. The Critical Area is defined as all land and water within 1000 feet of the mean high waterline. Forestry operations are regulated by law in this area. Additionally, Stand 4a is the 100 foot Habitat Protection Area and is covered by specific regulations. No forestry work is required in the Habitat Protection Area.

Due to the adequate stocking of the stand and the presence of the streams and wetlands, it is recommended that this stand continue to serve as a riparian forest buffer. The trees absorb nutrients such as nitrogen and phosphorus before they reach the streams and wetlands. The duff layer on the forest floor, composed of dead and decomposing leaves, slows the overland flow of water and reduces erosion. The tree roots serves as anchors, holding the soil in place along the stream bank.

English ivy and Japanese honeysuckle are present throughout the stand. These vines should be removed using the methods described in the Stand #1 Recommendations. The only exception should be the exclusion of herbicides in the stand due to the proximity of the wetland and Lake Ogleton.

Please note that the Mixed Alluvial Land (Mt) soil type found in this stand is classified as a hydric soil. A hydric soil is one that, in its undrained condition, is saturated, flooded, or ponded long enough during the growing season to favor the growth and regeneration of hydrophytic vegetation.

Except for the vine removal, allow the stand to grow for fifteen years (2019). At that time, the stand should be re-examined to update the management recommendations.

STAND DESCRIPTION AND RECOMMENDED PRACTICES

STAND NUMBER: 5 & 5a

AREA ACRES: 7.1 & 0.8

DOMINANT OVERSTORY SPECIES: Hickory, sweetgum, southern red oak

DOMINANT UNDERSTORY SPECIES: English ivy, Japanese honeysuckle, greenbriar

TIMBER SIZE: Sawtimber

AGE: even (60-75 years)

STOCKING: fully stocked (97%)

GROWTH POTENTIAL: fair

SOIL: Colemantown Silt Loam (Cm), Evesboro Loamy Sand (EoB), Monmouth Loamy Sand (MuB2), Monmouth Fine Sandy Loam (MvE)

RECOMMENDATIONS/PRACTICES:

This 7.9 acre stand is composed mainly of sawtimber sized hickory (26%), sweetgum (24%) and southern red oak (14%). Tulip poplar, white oak, black cherry, northern red oak and osage orange are scattered throughout. The tree density (or stocking) in this stand is adequate in relation to maintaining the optimum growing space per tree. This means that each tree has enough light, space, nutrients and water to grow properly.

This stand is located in the northeastern portion of the property. Portions of this stand border two tidal wetlands (E1OWL & E2EM5P) and a portion of Lake Ogleton. Currently, this stand is fully stocked and is growing well. The terrain slopes downward towards the lake. The entire stand lies within the Critical Area. The Critical Area is defined as all land and water within 1000 feet of the mean high waterline. Forestry operations are regulated by law in this area. Additionally, Stand 5a is the 100 foot Habitat Protection Area and is covered by specific regulations. No forestry work is required in the Habitat Protection Area.

The stand is currently growing adequately (site index 64 for southern red oak). However, in three years (2007) it has been calculated that the stand will become overstocked. At that time, each tree will not have enough sunlight, water, growing space, and nutrients to grow properly and growth rates will start to diminish. Starting in 2007, the stand should undergo a Timber Stand Improvement (TSI) in the form of a light basal area thinning. The residual basal area after thinning should be no less than 100 sq. ft/ac. This will allow the remaining trees to continue to grow properly. The trees to be removed should be of poor form and quality (i.e. crooked, forked or leaning). The trees can either be girdled or cut and felled. See the Stand #1 Recommendations for information about girdling.

English ivy and Japanese honeysuckle are present throughout the stand. These vines should be removed using the methods described in the Stand #1 Recommendations. The only exception should be the exclusion of herbicides on those portions of the stand that border Lake Ogleton and the wetlands. Vine removal should begin immediately and should continue until all vines have been eradicated.

Please note that the Colemantown Silt Loam (Cm) soil type found in this stand is

classified as a hydric soil. A hydric soil is one that, in its undrained condition, is saturated, flooded, or ponded long enough during the growing season to favor the growth and regeneration of hydrophytic vegetation.

The TSI should be conducted at a rate of 1.0 acres/year and should be completed by January 2014. After the TSI is completed, allow the stand to grow for five years (2019). At that time, the stand should be re-examined to update the management recommendations.

MANAGEMENT PRACTICE SCHEDULE

<u>COMPLETION DATE</u>	<u>PRACTICE</u>	<u>STAND</u>	<u>ACRES</u>
January 2015	Basal Area Thinning TSI	5	7.1 (~1.0 ac/year)
January 2019	Basal Area Thinning TSI	1	63.6 (5.3 acres/year)

Continuous	Vine Control/Removal	All	90.65
Continuous	Maintain Property Boundaries	All	90.65
Continuous	Monitor for Insect and Disease	All	90.65
Continuous	Maintain Roads and Trails	All	90.65
January 2019	Re-examine to Update Management Recommendations	All	90.65

To provide you with further assistance in carrying out the recommended practices please contact Brian Stupak, Project Manager, Maryland DNR-Forest Service, 6904 Hallowing Lane, Prince Frederick, MD 20678. Phone: 410-535-1303.. E-mail: bstupak@dnr.state.md.us

ADDITIONAL COMMENTS

1. The Project Forester is available to help the landowner initiate the recommended practices. Contact must be made at least six months before the scheduled practice is to be completed.

2. It is the landowner's responsibility to file this plan with the State Department of Assessments in Anne Arundel County in order to receive a reduced tax assessment to an agricultural/woodland level. This plan must be filed before July 1 of the taxable year. In order to maintain the reduced assessment the landowner must participate in the recommended practices.

3. For any future commercial harvesting activities that may be recommended, you should consider retaining a consultant forester to assist you. There are several good reasons for this. Nationwide, statistics show that landowners who retain a consulting forester receive about double the income from a forest harvest than landowners who do not retain a consulting forester. Additionally, hiring a consultant forester relieves you of worrying about all the details of a harvest, such as contracts, inspections, legal permits required, etc., which can be handled by the consultant forester. Most importantly, by hiring a forester to administer a harvest according to a management plan, you can be assured the condition of the woodland following the harvest will continue to be productive and valuable. Contact the forestry office for a list of private consulting foresters licensed to practice forestry in Maryland.

4. A Sediment and Erosion Control Plan is required prior to beginning a commercial timber harvest operation.

5. Upon request, the Maryland Forest Service will lay out a logging road system, mark trees to be removed during Timber Stand Improvement operations and provide technical assistance for the best management of the property. There is a nominal fee for marking the trees (\$12.00/acre). A private consulting forester should be contacted to administer all commercial sawtimber sales. A list of private consulting foresters licensed to practice in Maryland is available from the Project Forestry Office.

6. Boundary location and marking is essential in order to eliminate the potential threat of timber trespass during active timber cutting operations, and will deter unwanted intruders. Boundary lines should be clearly marked with blue paint at eye level facing away from the property. A law passed a few years ago makes posting land much easier and cheaper by allowing the use of vertical strips of blue paint as an alternative to signs. Article 27, Section 576-576A states that paint marks must be at least 2 inches in width and 8 inches in length, and centered from 3 to 6 feet from the ground or water surface.

7. Tree seedlings are available at cost to landowners for reforesting cut over areas, afforesting old fields or improving wildlife habitat. Contact the project forester for ordering and planting details.

8. Cost-share assistance may be available through state cost-share programs to help pay for a portion the expenses associated with implementing the forestry or wildlife management activities in this plan. Contact the forestry office for further information.

9. Portions of this property fall within the Critical Area. The Critical Area includes all land and waters within 1000 feet of the mean high water line. Forest harvesting is specifically regulated under the Critical Area Law. Additionally, the first 100 feet of forest buffer from the Chesapeake Bay is considered a "Habitat Protection Area" and is covered by specific regulations. Non-tidal wetlands within the Critical Area are also covered by the Critical Area Law. The landowner should contact the forestry office for more detailed information on the Critical Area regulations as needed. The Anne Arundel County Forest Conservancy District Board must review all commercial timber harvesting in the Critical Area.

WILDLIFE MANAGEMENT RECOMMENDATIONS

Prepared by
Brenda Belensky, Erin Deneke, Jeff Feen
Stewardship Biologists

INTRODUCTION

It is the goal of the Forest Stewardship Program to work with concerned landowners to

enhance existing habitat for wildlife. Your interest in helping to provide quality habitat for wildlife species is encouraging. The land you own definitely has the potential to provide the necessary habitats needed by wildlife to survive year round.

Providing safe nesting cover and structures, and ample summer and winter food near existing winter cover is the basis of much of the following wildlife management recommendations:

SNAG MANAGEMENT

Cavity nesting birds such as woodpeckers, chickadees, titmice, great-crested flycatchers and bluebirds nest in tree cavities which they excavate themselves or which were excavated by other cavity nesting birds. Therefore, the limiting factor for these birds is the number of standing dead trees that are suitable for nesting. The ideal density of standing snags is an average of 10-20 small snags and 2-5 large (>12" diameter) snags per acre. Homeowners can help cavity nesting birds by only cutting down snags that are endangering their vehicles or homes. Where possible, all other snags should be allowed to stand until they fall down of their own accord. In addition to providing nesting habitat, snags provide feeding areas for many birds throughout all stages of decay.

Where the number of snags is below optimum, you can create snags by girdling trees in the manner prescribed by your forestry plan. Live trees with existing cavities should be left as they are more beneficial and the cavities last longer than cavities in dead trees. Also, healthy mast trees (i.e., oaks and hickories) should not be cut as they produce nuts that are beneficial to many species of forest wildlife.

FIELD EDGE MANAGEMENT

Introduction:

Studies have found that larger numbers and a greater variety of wildlife occur where forest and field meet than in either the forest or field. Biologists call this phenomenon the "edge effect" and believe it takes place because a greater diversity of food and cover exists near the edge between habitats. Edges also exist where fields border ditches, hedgerows, or field roads, and where fields containing different types of vegetation or crops meet. The following sections discuss methods to improve this effect at field borders, with recommendations for herbaceous, shrub, and cut-back borders, and important considerations in managing field edges.

Herbaceous Borders:

Strips containing grasses and legumes or native annuals and perennials along permanent cover can serve as nesting areas for ground nesting birds. Seeds produced by the mixture, as well as insects and small rodents attracted to the mixture, will also provide food for many species of wildlife.

Herbaceous borders should be a minimum of 50 feet wide along the woods and 10 feet wide along ditches, field roads, and fence lines with permanent cover. Prepare a seed bed when frost leaves the ground in spring by plowing, discing, and dragging or harrowing. A soil test performed by the Maryland Cooperative Extension Service is necessary to determine the amount

of lime and fertilizer to be used to establish the border. To establish the pasture mix, lime and fertilize according to the soil test results and follow standard agricultural practices to establish the following mix as you would a hay crop:

White Dutch or
Ladino Clover 4lbs/ac
Orchard Grass 5lbs/ac

Plant the above mix from March 1 to May 15 or from August 1 to September 30. Grass-legume mixtures (Table 1) should be seeded using a drill or Brillion seeder. All legume seeds (clovers, alfalfa, and all the lespedeza) must be treated with the proper commercial inoculant prior to planting. If needed, further technical assistance is available from the Cooperative Extension Service in your county.

Maintain your pasture mix and control woody plants by mowing 2 to 1/3 of your pasture mix acreage each summer during the month of August. Mowing in August permits regrowth prior to winter so that these areas will be suitable for nesting the following spring. However, mowing prior to August is likely to destroy nests and may injure young rabbits.

Native annuals and perennials will invade if the strip remains fallow; these are beneficial to wildlife. Mow every two to four during the month of August to reduce density and to prevent encroachment of brush. Only 1/3 to 2 of a border or alternating 300-ft. segments should be mowed in any one year. Areas 1/10 to 1/4 acre may be mowed more frequently for rabbits.

State law requires that you control noxious weeds (Johnson grass, Canada thistle and shattercane) on your property. If you are having problems with these species, contact your county extension agent to explore the possible alternatives. I recommend that you use spot-spraying or spot-mowing where possible to control these weeds.

Shrub Borders:

Shrub borders provide wildlife food and cover, serve as fences, establish contour guidelines, provide screens, and help to delineate field boundaries. They also provide permanent cover adjacent to herbaceous borders.

Examples of species to be planted and their spacing are presented in Table 1. Depending on space allocated, shrub borders should be a minimum of one to five rows wide. Plow or disc the fall preceding planting or scalp the sod just prior to planting. Fertilize and lime according to a current soil test and plant as soon as frost leaves the ground in the spring. Plants should be placed in a hole wide and deep enough to accommodate the roots in a natural manner at the nursery planting depth or the root collar. Mulching each plant with straw, old hay, or plastic will improve survival percentage.

Another technique is to plant clumps of shrubs and trees in open field corners, ditch intersections, or other odd areas. This will provide valuable food and cover while using a minimum of 600 square feet with at least 50 percent in the center planted to dense-growing evergreens.

All shrub borders should be worked two years after planting and every five years thereafter to remove undesirable trees and shrubs. The tops of evergreen trees should be clipped off to cause them to bush out.

Cut-back Borders (Woodland Edges):

Herbaceous and shrub borders can be created without a loss of valuable cropland by cutting back the woods edge. Herbaceous borders can be formed by clearing all trees flush with the ground. Natural shrub borders can be established by removing low value woody plants that are more than one inch in diameter at breast height, while leaving oaks, hickories, beech, wild cherries, dogwood, any den trees, or other trees valuable to wildlife. Shrubs of high wildlife value (Table 1) may be planted where needed to increase the value of cut-back borders of shrubs.

Minimum width of herbaceous borders should be 50 feet, and shrub borders should be 25 feet. Cut-back borders should be maintained in the same manner as described in the two previous sections. (Note: Cut-back borders cannot be used within the 100 foot buffer of the Chesapeake Bay Critical Area).

Important Considerations:

Two important considerations are to create a diverse and "soft" edge. Plants which fruit or seed during different seasons will provide food all year. It is necessary to plant several species which provide winter food if other sources are scarce. Evergreens, mixed with deciduous plants, will ensure that adequate cover is available during storms or harsh winter weather. An irregularly shaped border produces more edge than a straight border. Lastly, a diversity in sizes of plants is important because different wildlife species use various heights occurring at the edge and a single species may use different sizes for various biological functions such as feeding, nesting, and roosting. Figure 1 illustrates a "hard" and "soft" edge. A soft edge has vegetation that gradually increases in size whereas a hard edge has small plants adjacent to large. Soft edges are used to a greater extent by wildlife than are hard edges. Soft edges can be created either by planting or through the use of cut-back borders.

Turkey:

Turkeys may range up to 4000 acres daily. When an appropriate interspersed of habitats is available, they may confine their daily activity to 400-1000 acres. Prime range is characterized by a diversity of forest types and age classes, predominated by mature hardwoods, well interspersed with small openings and some cultivated land. Thus, your property alone will not support turkeys. However, in conjunction with surrounding properties, all of the habitat requirements may be present.

The following are recommendations for the forest on your property. A variety of mast producing trees should be maintained including oaks, beech, cherry and ash. Grape thickets, briar patches, spring seeps, and small streams should all be protected because of their value as sources of food during winter. Grazing by deer should be kept at a level so that food-producing plants are not destroyed and there is minimal competition for mast. This may require harvesting deer on your property if population levels are too high in the area. Lastly, turkeys are very susceptible to human disturbances and disturbances from free ranging dogs. Therefore, every effort should be made to limit these disturbances.

Rabbits:

The cottontail rabbit is found throughout the state and is easily managed. They require good cover near food and a place to bear young. Home ranges of rabbits generally consist of 5 to 10 acres for males and 3 to 4

acres for females. They spend most of their life within 150 feet of dense brushy cover. Food supply for cottontails is generally adequate since they eat a great variety of plant foods. Rabbits need unmowed grass for nesting cover, grasses and legumes for food, dense brush and vines for escape cover and winter food. Planting clover plots or incorporating clover into the existing grass would be of help. Leaving uncut or overgrown brushy areas provide both escape and winter cover. The same browse areas created for deer also benefit rabbits. Since rabbits nest on the ground, the young are very vulnerable. Controlling stray cats will help greatly.

Squirrels:

Squirrels depend on a good mast crop for their survival, including the fruits of such species as oaks, hickories, beeches, and walnuts. Therefore, any management practice that would help the mast crop is desirable. Since no one species can be depended upon for an annual mast crop, a variety of mast producing trees should be encouraged.

Besides food, the limiting factor affecting squirrels is good den trees for nesting sites. Enclosed is a note describing construction and placement of squirrel nest boxes.

Brush Piles:

Brush piles can provide important escape cover for many small animals. Please refer to the enclosed reference material on how to build brush piles included with this plan. You could build several large brush piles along your woodland edge.

FOREST MANAGEMENT NOTES

NON-COMMERCIAL TIMBER STAND IMPROVEMENT

Timber Stand Improvement (TSI) is a term that applies to all cultural operations made in an immature stand of timber to increase its rate of growth and improve the quality of the residual trees. Through TSI operations a forester can manipulate stand densities and regulate tree growth. By reducing stand density, it is possible to stimulate the growth of the remaining trees and concentrate the volume on a small number of more valuable trees.

Two major objectives of TSI are:

- (1) increase or maintain a high growth on the more desirable trees
- (2) improve the quality of the remaining stand by reducing the number of defective, deformed and undesirable trees.

Improvement operations are made in stands from 15 to 50 years of age. These operations should be carried out in well-stocked stands on good sites supporting desirable species. Research has shown that there are

excellent benefits from doing TSI. The time required to grow a tree to maturity can often be reduced by as much as 50 percent in stands that receive improvement thinnings at an early age and at regular intervals. The amount of useable wood from stands that have received regular TSI thinnings can be increased by 50 percent.

When the trees cannot be sold or used by the property owner, there are three methods for removing them from competition -- girdling, frilling and applying a chemical, and injection with a chemical.

- Girdling involves cutting a ring around the tree to a depth of 1 to 12 inches depending upon the species.
- Frilling is done by making overlapping cuts around the tree and applying a chemical herbicide to the cut.
- The injection method is carried out by use of special tools such as the "Tree Injector" or the "Hypo-Hatchet". Injections of a chemical herbicide are made at spaced intervals around the tree.

The forester will describe these methods in more detail and recommend the one which would best meet the conditions for your property. TSI operations should be planned and carried out under the supervision of a forester. Your forester will be available to designate the trees to be removed and to assist you in carrying out your TSI operation.

FOREST MANAGEMENT NOTES

**CHESAPEAKE BAY CRITICAL AREA
FOREST BUFFER MANAGEMENT**

The Chesapeake Critical Area Law requires that a minimum of 100 foot vegetated buffer strip landward from the Mean High Water Line of tidal waters, tributary streams and tidal wetlands be established. The strip shall be expanded by a distance of four feet for every one percent of slope for slopes greater than 15 percent.

“**BUFFER**” – An existing, naturally vegetated area, or an area established in vegetation and managed to protect aquatic, wetlands, shorelines and terrestrial environments from man-made disturbances.

Forestry practices within the 100 foot Buffer are restricted. No forestry practice is permitted within the first 50 foot strip except for the following:

- (a) Cutting of trees or removal of natural vegetation may be permitted where necessary to provide access to private piers or to install or construct a shore erosion protection device or measure, or a water dependent facility, providing the device, measure or facility has received all necessary state and federal permits.

- (b) Individual trees may be cut for personal use providing that this cutting does not impair the water quality or existing habitat value or other functions of the Buffer and provided that the trees are replaced on an equal basis for each tree cut.
- (c) Individual trees may be removed which are in danger of falling and causing damage to dwellings or other structures, or which are in danger of falling and therefore causing the blockage of streams, resulting in accelerated shore erosion.
- (d) Horticultural practices may be used to maintain the health of individual trees.
- (e) Other cutting techniques may be undertaken, if necessary, to preserve the forest from extensive pest or disease infestation or threat from fire. Advice and guidance must be obtained from the Department of Agriculture and/or Natural Resources.

Commercial harvesting of trees by selection or by the clearcutting of Loblolly pine (*Pinus taeda*) and Tulip poplar (*Liriodendron tulipifera*) may be permitted to within 50 feet of the landward edge of the Mean High Water Line of the tidal waters and perennial tributary streams, or the edge of tidal wetlands, provided that this cutting does not occur in the following Habitat Protection Area: Non-tidal wetlands, Wildlife Habitat and Anadromous Fish Propagation Waters. A buffer management plan prepared by a registered, professional forester and approved by the Maryland Forest Service is required for all commercial harvests within the Buffer, regardless of the size of the area to be cut.

The plan shall contain the following minimum requirements:

- (a) That disturbance to stream banks and shorelines shall be avoided.
- (b) That the area disturbed or cut shall be replanted, or allowed to regenerate in a manner that assures the availability of cover and breeding sites for wildlife and re-establishes the wildlife corridor function of the Buffer.
- (c) The cutting does not involve the creation of logging roads and skid trails within the Buffer.

FOREST MANAGEMENT NOTES

Invasive Vines and Weed Species

Controlling invasive vines and shrubs in the forest can be a difficult and expensive operation. In Maryland, there are twelve different plants that are considered noxious and should be controlled if possible. Control of these plants can be accomplished through mechanical or chemical means if proper procedures are followed. Most weed species whether trees, shrubs, vines, or grasses, get established in open areas where there is plenty of sunlight. Ecologically these species can generally be called pioneer type in that they establish themselves in areas where no other plants have such as fields and road sides. Another area where they become established easily is recently harvested forest land where the trees have been either clearcut or thinned such that the canopy is open enough to let light reach the forest floor. Care should be taken to monitor recent harvest to prevent establishment of these species as they can severely limit regeneration of the forest by choking out seedlings and sprouts.

There are five species, all introduced, that cause considerable problems. In Maryland, the most widespread species is **Japanese Honeysuckle**(*Lonicera japonica*). Japanese Honeysuckle is a smooth leaved semi-evergreen vine, often found twining around small trees and shrubs or trailing along the ground. The fragrant white flowers appear in July and last through September. The black fruits ripen in August and September and persist until March. Originally planted as an ornamental and for erosion control purposes it is found throughout Maryland. Control of Japanese Honeysuckle is difficult. The vines are very difficult to mow and the waxy coating on the leaves inhibits absorption of chemicals. It is often necessary to cut the vines, wait until regrowth begins, and then use a foliar spray. (see table for chemicals used)

Multiflora Rose(*Rosa multiflora*), was another species introduced for erosion control purposes. A cousin of the ornamental rose species, it was also planted for hedges, screens and living fences. Found throughout Maryland it is a

spreading shrub that grows to ten feet high with large drooping canes. Armed with heavy thorns, this plant flowers with abundant clusters of white simple flowers. The plant can also be recognized by its compound leaves have nine leaflets. Although this shrub provides excellent wildlife cover for many birds and animals, it can overtake clearings preventing trees and other shrubs from regenerating.

Kudzu(*Pueria lobata*), is a fast growing perennial vine that was imported from eastern Asia for erosion control purposes. This vine has been likened to a scourge, overtaking fields and whole stands of trees. Extremely difficult to kill, it usually takes two and sometimes three or more applications of potent herbicides to kill. A tough vine with alternate trifoliolate leaves it will often form a blanket over shrubs, trees and even buildings. If you suspect you have this vine growing on your property contact the Project Forester for help.

Mile-a-minute(*Polygonum perfoliatum*), also called tearthumb, is another east Asian import. It is an extremely fast growing climbing vine that possesses sharp prickles. Light to medium dark green, it has triangular leaves that grow without a stalk or petiole. Control of this vine can be either through mowing or by use of chemicals. Either method should be done in mid summer before the seeds develop. The plant will die back when the first frost occurs. However, if seeds had time to form it will regrow the next year.

Tree-of-Heaven(*Ailanthus altissimo*) of *A Tree Grows in Brooklyn* fame, is a large tree with suckering roots that originally came from China. This tree has large feather compound leaves with stout branches. The leaves and branches have a strong, foul odor when crushed. Ailanthus is very difficult to control and requires specific treatments according to size and condition. Contact the Project Forester for assistance.

Since many of the herbicides recommended are in the restricted use category, meaning you need a pesticide applicators license to apply them, contact the Project Forester for a list of certified applicators. In addition there may be cost-share assistance available through the Stewardship Incentive program, WIP, or other federal and state programs that can pay up to 65% of the cost of the practice. Invasive vines and other weed species can be controlled silviculturally by limiting the amount of sunlight that reaches the forest floor. The species listed are just a few of the dozen or so weed species encountered in Maryland. For more information check with your cooperative Extension Service Agent or Project Forester.

Control Methods* restricted use herbicide			
Species	Mechanical	Chemical	Notes
Japanese Honeysuckle (<i>Lonicera japonica</i>) Oriental Bittersweet (<i>Celastrus orbiculatus</i>)	No	2,4-D, 2,4-D+dicamba *Arsenal *Crossbow *Garlon 3A,4 Roundup/accord	follow-up spray often needed
Multiflora Rose (<i>Rosa multiflora</i>) & Bush Honeysuckles (<i>Lonicera spp.</i>)	mow	2,4-D + dicamba *Arsenal AC, Crossbow, *Escort\Ally *Garlon 3A,4 Roundup\accord	thorough coverage of plant is important
Kudzu (<i>Pueria lobata</i>)	usually not effective	Treatments: (1-2 times) *Arsenal AC (at least twice) 2,4-D + dicamba *Garlon 3A, 4	use surfactant

		(3 times or more) Roundup/Accord	
Mile-a-minute (Polygonum perfoliatum)	mow before seed development	pre-emerge: *Aatrex 4L, *Arsenal AC, *Oust, *Princep liquid, *Velpar L post-emerge *Arsenal AC *Crossbow, *Garlon 3A, 4, Roundup/Accord	Use of a surfactant is essential.
Tree-of-Heaven (Ailanthus altissimo)	Contact Project Forester		

In Anne Arundel County contact the Project Forester at: (410) 360-8421.

Maryland Department of Natural Resources

FOREST SERVICE

FOREST MANAGEMENT NOTES

PROTECTING THE FOREST FROM WILDFIRE

Maryland's forest lands are under the constant threat of damage caused by wildfire. The main causes of wildfire in Maryland involve human activities such as: debris burning, arson, equipment use, and children playing with fire.

Wildfire damages woodlands not only by killing trees outright, but also by destroying seeds and seedlings. Entire forest reproductive cycles can be wiped out by one brisk wildfire. Fire damages larger trees by leaving wounds that heal slowly and provide a point of entry for insects and diseases. Wildfire damages not only trees but affects the soil and water quality. Burning off the litter layer exposes the soil to the effects of wind and rain, the resulting soil erosion may choke creeks and streams. Fire endangers homes and utilities in wooded settings, causing thousands of dollars in damage. A well maintained road system in your woodland aides in stopping fires by creating a fuel break and by providing a means of quick access for firefighters.

The Maryland Forest Service enforces open air burning regulations. The following regulations apply to those activities occurring within 200 feet of a woodland, or those activities adjacent to flammable materials that could ignite and carry fire to a woodland.

***** OPEN AIR BURNING REGULATIONS *****

A person may not engage in open air burning except under the following conditions:

1. There is a natural or constructed firebreak at least 10 feet wide completely around the material to be burned that is free of flammable material.
2. Adequate personnel and equipment are present to prevent the fire from escaping.
3. At least one responsible person remains at the location of the fire until the last spark is out.
4. Burning occurs during the hours of 4:00 pm and 12:00 midnight E.S.T., except when the ground is covered with snow allowing burning to occur at any time as long as other requirements are met.

NOTE!: OPEN AIR BURNING IN ANNE ARUNDEL COUNTY IS ILLEGAL AT ANYTIME WITHOUT A PERMIT. Local Environmental Health Department regulations should be checked prior to burning.

If you have further questions concerning the protection of forest land from wildfire, contact your local Forestry office at 410-360-8421.

Maryland Department of Natural Resources

FOREST SERVICE

FOREST MANAGEMENT NOTES

WHAT ARE FIDS?

Forest Interior Dweller species (FIDs) are an important component of Maryland forests. There are 19 species of birds found here in Maryland. These birds all have one thing in common in that they require large tracts of relatively undisturbed mature hardwood forests as breeding habitat. The loss of these forests and the fragmentation of the remainder due to agriculture and increasing urbanization is the leading threat to these birds. Competition from edge species which arrive earlier or are year round residents, parasitism by brown headed cowbirds, and predation by edge species like blue jays and raccoons take a heavy toll on the population. Critical habitat for these birds is the interior forest canopy where competition from edge species is limited. A large tract of woods does not guarantee FID species although it can encourage or promote them with good forest stewardship practices that encourage structural diversity in the forest and maintain a crown closure of 70%. Regeneration harvests on areas of 100 acres or more are not detrimental as long as the harvest is kept to the edges of the forest and is done in small areas (<25 acres).

Conservation of FID habitat is required within the Chesapeake Bay Critical Area and recommended in other areas. The following are management recommendations for FIDs that should be considered when forest management operations are planned.

- 1) Minimize forest disturbances during the breeding season (May 1 - August 31) whenever possible.
- 2) The forest canopy should not be removed in excess of 70% crown closure with

selective cutting or timber stand improvement practices.

- 3) Retain or encourage snags 10 inches diameter at breast height or greater. Cluster snags where possible. Snags that protrude above a closed forest canopy should be removed.
- 4) Maintain forested buffers along streams and shorelines. Daylighting (widening) of access roads in forest interiors should be discouraged.

If you have any questions concerning FID species or habitat or think they might be present on your property please call your local forester or biologist.

Forest Interior Breeding Birds of Coastal Maryland

Red Shouldered Hawk*	Pileated Woodpecker	Northern Parula
American Redstart*	Ovenbird	Scarlet Tanager
Barred Owl*	Acadian Flycatcher	Black-and-White Warbler
Prothonotary Warbler	Louisiana Waterthrush	Swainson's Warbler*
Whip-poor-will	Yellow-throated Vireo	Hooded Warbler
Worm-eating Warbler*	Kentucky Warbler*	*species especially sensitive to disturbance
Hairy Woodpecker	Red-eyed Vireo	

Maryland Department of Natural Resources

FOREST SERVICE

FOREST MANAGEMENT NOTES

BRUSH PILES

One of the most critical habitat requirements for many species of wildlife is cover. Many animals need dense cover throughout the year for various reasons such as concealment and protection from predators, protection from weather, and for resting or loafing cover. In areas where dense tangles of brush and vines are not common, the creation of artificial brush piles can provide much needed cover for ground nesting birds, rabbits, songbirds and other small animals.

Brush piles can be constructed along forest edges, in openings, in field corners, or along the margins of streams and marshes. Brush piles should be situated near grassy areas or cultivated lands so that food and nesting areas are close by. In open areas where cover is lacking, up to three to four brush piles per acre should be constructed. Along woodland borders, one brush pile every 200 to 300 feet will provide adequate cover.

Brush piles should be built in conjunction with forest thinning or harvesting operations. The materials used for the brush pile will depend upon what is available on site. Rot resistant trees such as oaks and locust make durable bases for the brush piles. The base of the brush pile should be formed by placing alternate layers of logs at right angles to one another. The logs used should be at least six inches in diameter and spaced six to ten inches apart in each layer. To increase the durability of the brush pile, the base layers may be stacked on top of stones, cinder blocks, or around large stumps.

A properly constructed base will keep pathways open under the pile once the brush is placed on top.

Smaller trees and brush should be piled on top of the base until a mound or tepee shaped brush pile is created. Any type of brush may be used as filling on the piles, but evergreens will provide excellent cover for a number of years. Finished piles should be four to eight feet tall and ten to twenty feet across. If you choose to build a rectangular shaped brush pile, it should be at least ten feet wide and twenty-five feet long.

Remember to build the brush piles dense enough in the center to provide adequate shelter from adverse weather and predators, but loose enough around the edges to allow for easy access. Strict attention should be given to the size of the brush piles built. Most people make brush piles too small. If a person can kick a brush pile over, or a dog can burrow through them, they are too small.

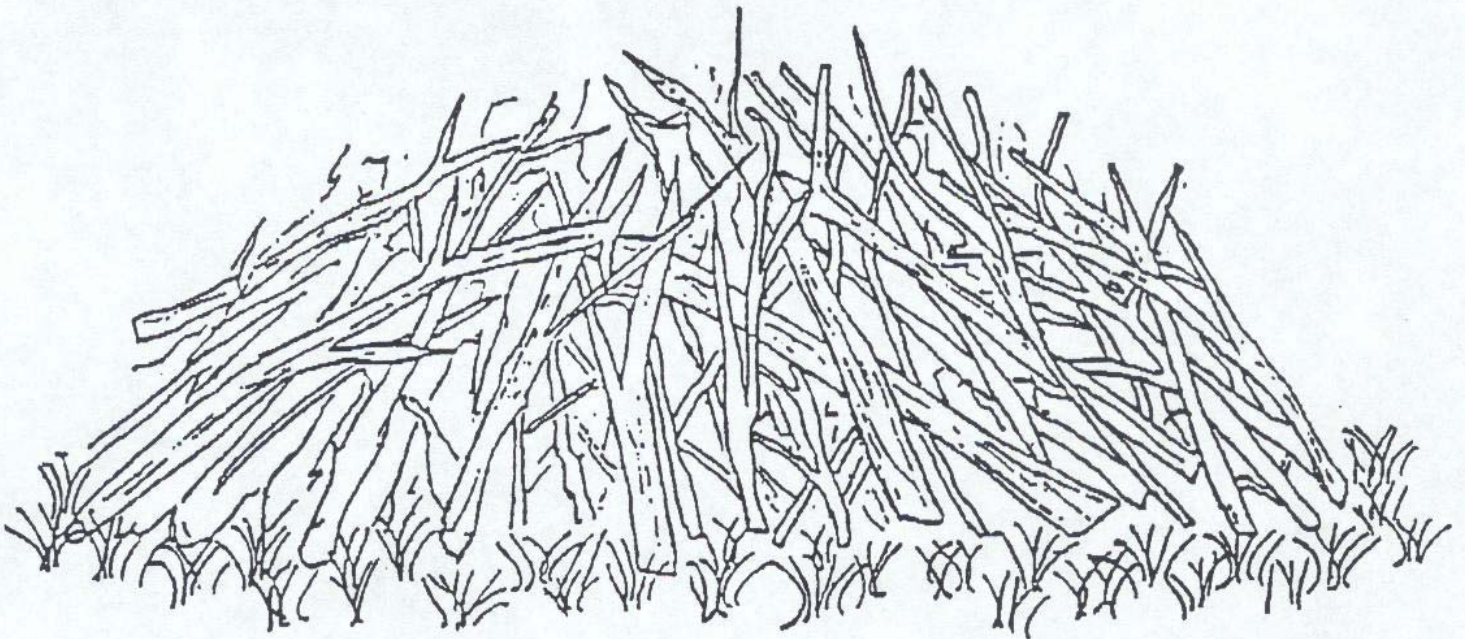

FINISHED BRUSH PILES = WILDLIFE HABITAT

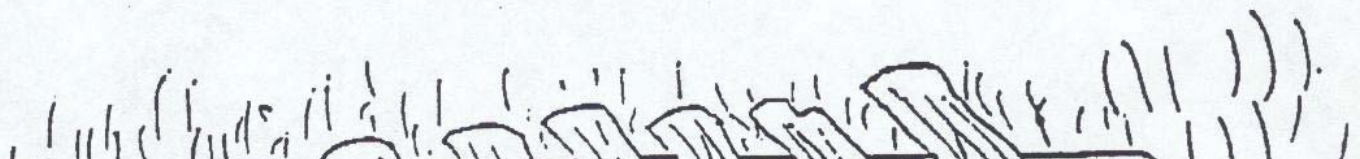

FOREST MANAGEMENT NOTES

SQUIRREL NEST BOXES

Squirrel populations may be increased in young saw timber stands where natural nest cavities are scarce by putting up nest boxes. At least two den trees per acre are needed for good squirrel populations. In areas of young timber or where there are otherwise less than two den trees per acre, 2-3 nest boxes per acre should increase squirrel populations.

Squirrel Nest Box Specifications

Design specifications for a squirrel box are attached. A 3 inch square entrance hole is just large enough to permit squirrel use but excludes larger predators. A box depth of 1/4 inches or greater below entrance hole ensures that young squirrels are beyond the reach of raccoons and opossums.

A sloping roof with an overhanging side reduces that amount of water seeping into the box. By using cleats, roof warping is minimized. The roof should be removable to allow for cleaning. Drill drainage holes into the bottom of the box to allow water, which gets into the box, to drain out. One-inch treated pine boards or untreated rough-cut heart cypress or cedar boards can be expected to last 20-25 years. If treated boards are unavailable, use heart cypress or cedar. Do not paint boxes.

Hang nest boxes on a tree trunk, 10 or more feet above the ground; the higher the better. It is advisable that boxes be hung above, but not directly on, one or more large limbs to shield the box from vandalism. Placing a box directly on a limb increases breakage due to tree sway and may increase predation by tree-climbing snakes, such as the black rat snake.

Suspend boxes from the tree with a 20d - to -40d zinc-coated or aluminum nail through a wire loop on the back of the nest box. In the interest of timber values, select trees of low merchantability or cull value for boxes. Boxes should not be placed in trees already containing cavities; squirrels will not readily accept boxes if natural cavities are available in the same tree. To prevent rocking or excess movement, tie a single strand of No. 10 solid polyethylene-coated wire around the box and tree. This arrangement of nails and wire is adequate to secure a box, yet flexible enough to slip (1) with tree growth, or (2) if knocked by falling limbs. Tightly fastened boxes are more apt to be demolished by falling objects.

Maintenance

If boxes are constructed of treated boards or cypress and assembled using rustproof nails, an effective life expectancy of 20 to 25 years is probable. Painting is not encouraged. Maintenance of properly constructed boxes is reduced to periodic rehangng to permit tree growth and re-nailing if nails have worked loose every 2-3 years. Visually check boxes for damage annually in October and, if necessary, repair the box and promptly rehang for reuse. Leaf litter should be left in boxes, or cleaned out of not more than 25% of the boxes in any given year.

SQUIRREL NEST BOX

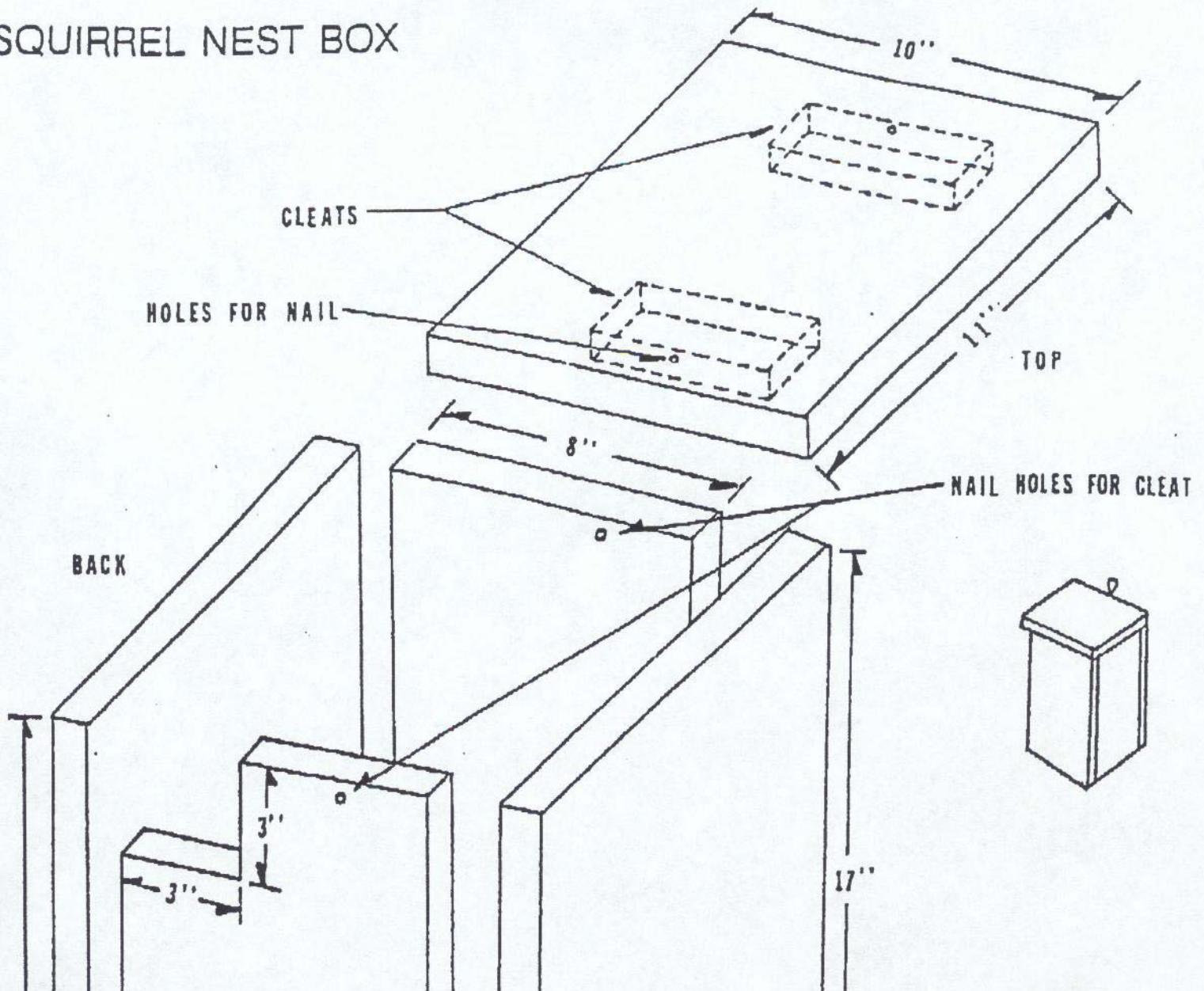

Table 1. Representative species to plant at field edges to benefit wildlife.

Layer	Species	Seedling rates or spacing ¹
grass-legume	orchard grass	2 lbs/acre
	Blackwell switchgrass	4 “
	reed canarygrass	6 “
	Korean lespedeza	20 “
	common lespedeza	20 “
	ladino clover	4 “
	alsike clover	4 “
small shrubs	blueberry	4' x 1.5'
	coralberry	“
	huckleberry	“
	blackberry	“
tall shrubs	tartarian honeysuckle	6' x 6'
	red osier dogwood	“
	graystem dogwood	“
	silky dogwood	6' x 4'
	amur honeysuckle	“
	autumn olive	“
	hazelnut	“

	American cranberrybush	“
	bicolor lespedeza	6' x 1.5'
small trees ²	flowering dogwood	8' x 8'
	American holly	“
	crab apple	“
	serviceberry	“
	staghorn sumac	“
	scotch pine	“
	black pine	“

¹Spacing is presented as space between rows x space between plants.

²Pines should be topped when they reach 4-6 ft. in height.

